

THE VOICE THE STANDARD THE RESOURCE

Safety Training for First Responders on ZEVs
February 2025



Overview

1. Introduction to Alberta Motor Transport Association (AMTA)
2. Class 8 Zero Emission Vehicles
 - Electric Vehicles (EV)
 - Energy Systems
 - Battery Electric Vehicles (BEV)
 - Fuel Cell Electric Vehicles (FCEV) hydrogen
3. NFPA Emergency Response Guides
4. Response to an EV Vehicle Fire
5. Risks
6. Resources

Safety Training for First Responders on ZEVs

Introduction

Alberta Motor Transport Association

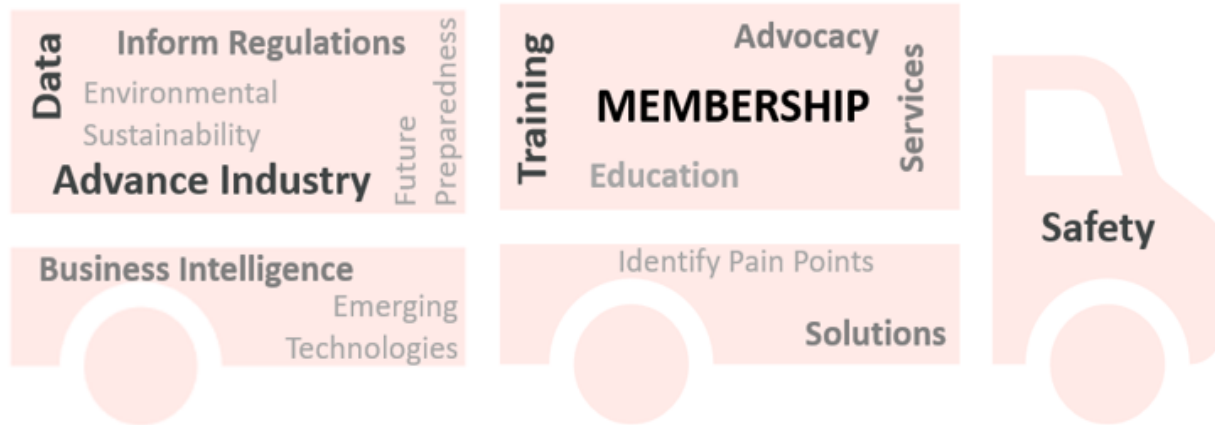

Transportation is one of Canada's largest GHG emitters.

AMTA will collaborate with a multitude of project partners to modernize Canada's energy system by supporting clean energy solutions.

<https://www.amta.ca/innovation-projects>

Hydrogen awareness • Early vehicle adoption • Hydrogen supply • Vehicle services, training, regulations

Emissions Reduction Projects

Alberta Zero Emissions Truck Electrification Collaboration (AZETEC)

Design, test and operate two heavy-duty FCEVs for Canadian weights, hydrogen production

Electric Vehicle Infrastructure Development (EVID)

Alberta's first hydrogen fueling station, hydrogen storage and dispensing

Zero Emissions Vehicle Awareness Initiative (ZEVAI)

Advance hydrogen industry awareness & training programs

Hydrogen Vehicle Demonstration

Introduce carriers to zero and reduced emission technology, H₂DF class 8 heavy-duty trucks

Mechanic Training

High voltage systems, fuel cells, hydrogen systems, drive trains

Zero Emissions Trucking Testbed

Stakeholder engagement sessions, training, zero-emission vehicle trials

<https://www.amta.ca/innovation-projects>

Zero Emission Truck Testbed (ZETT)

ROUTE ONE: BATTERY ELECTRIC VEHICLE (BEV)

ROUTE TWO: FUEL CELL ELCTRIC VEHICLE (FCEV)

Project partners

 Transport Canada Transports Canada

 **AMTA** Alberta Motor Transport Association

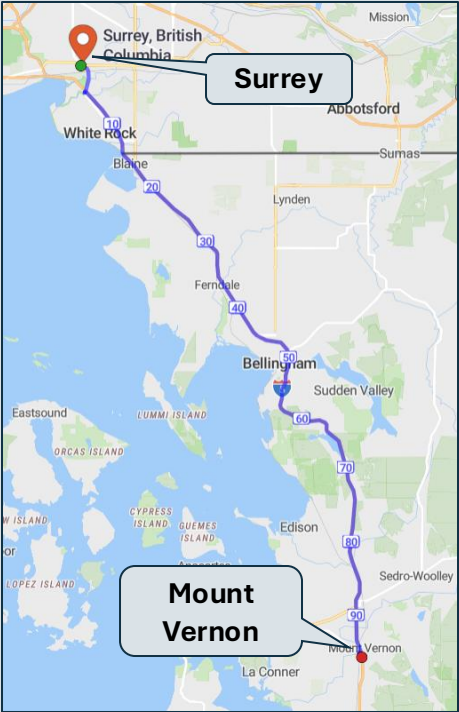

Deloitte.



Surrey

Mount Vernon

VOLVO



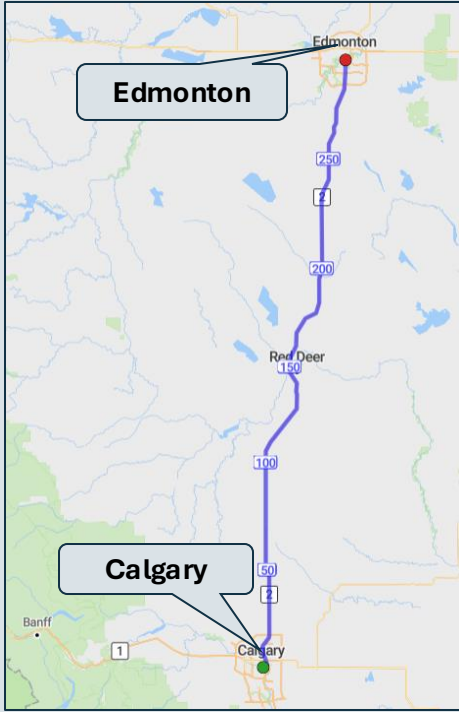

Volvo VNR Electric



Edmonton

Calgary

NIKOLA
MOTOR COMPANY





Nikola TRE FCEV

NIKOLA
MOTOR COMPANY



Nikola TREFCEV

AZETEC
ALBERTA ZERO-EMISSION TRUCK ELECTRIFICATION COLLABORATION



AZETEC FCEV 1

Safety Training for First Responders on ZEVs

Class 8

Zero Emission Vehicles

First Automobiles

Which vehicle was invented first?

A. Electric Vehicle

B. Hydrogen Vehicle

C. Gasoline Vehicle

Electric Vehicle: 1832 Robert Anderson

Hydrogen Vehicle: 1860 Etienne Lenoir

Gasoline Vehicle: 1886 Carl Benz 
1889 Gottlieb Daimler

Zero-Emission Vehicles

Conventional Vehicle vs Electric Vehicle

Internal Combustion Engine (ICE)

Electric Vehicle (EV)

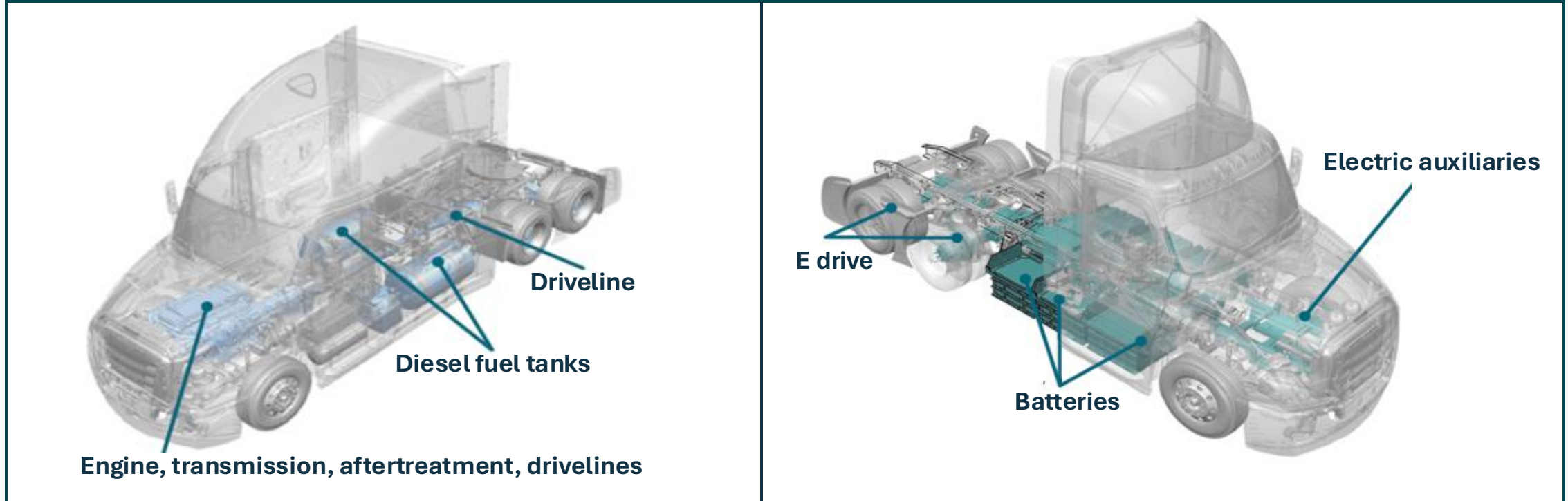

Zero-Emission Vehicles

Battery Electric Vehicle (BEV)

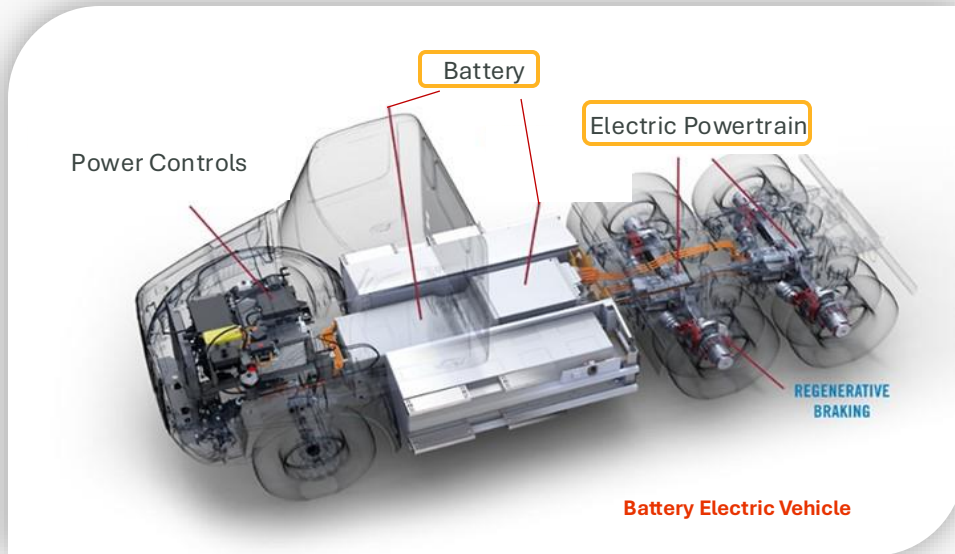

Fuel Cell Electric Vehicle (FCEV)

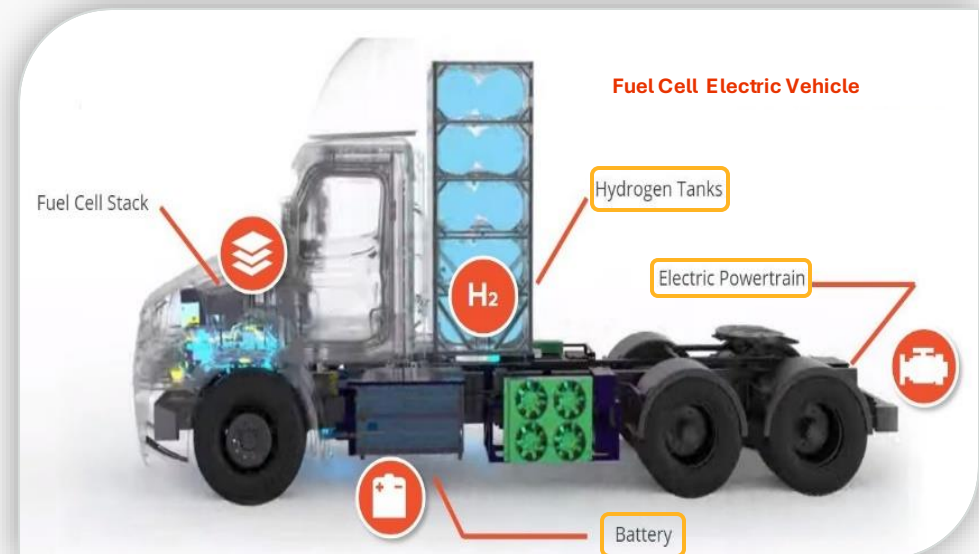

Hydrogen Internal Combustion Engine (ICE)

Zero-Emission Vehicles

Volvo Battery Electric Vehicle (BEV)

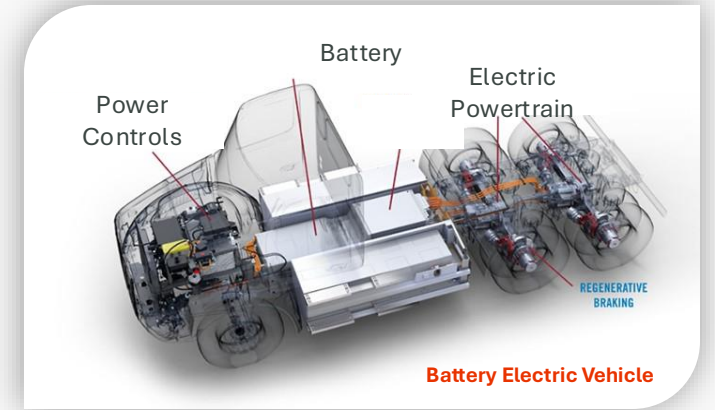

Zero-Emission Vehicles

Nikola & AZETEC Fuel Cell Electric Vehicle (FCEV)

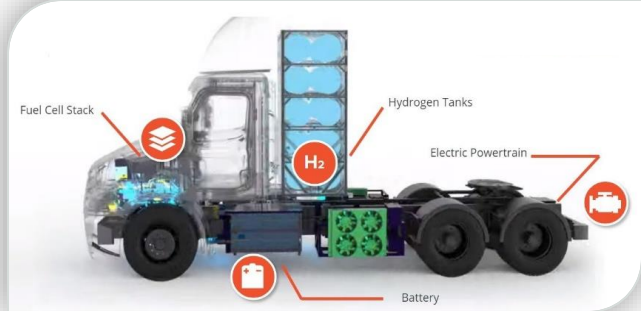

[AZETEC movie \(short\).mp4](#)

Zero-Emission Vehicles

Battery Electric Vehicle (BEV) vs Fuel Cell Electric Vehicle (FCEV)

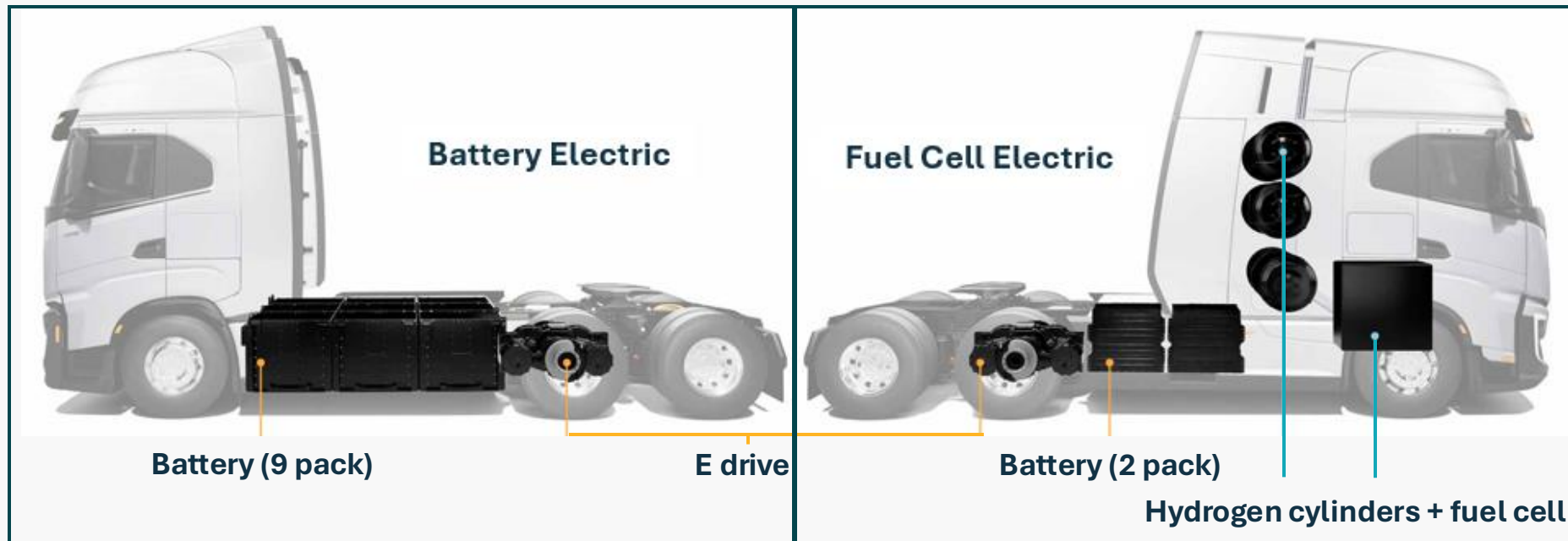

Zero-Emission Vehicles

Battery Electric Vehicle (BEV)



Cleantechica (2022). Tesla Semi Details Revealed in Parts Catalogue Diagrams Retrieved from:
<https://cleantechica.com/2023/01/05tesla-semi-details-reveale-in-parts-catalog-diagrams/>

Fuel Cell Electric Vehicle (FCEV)

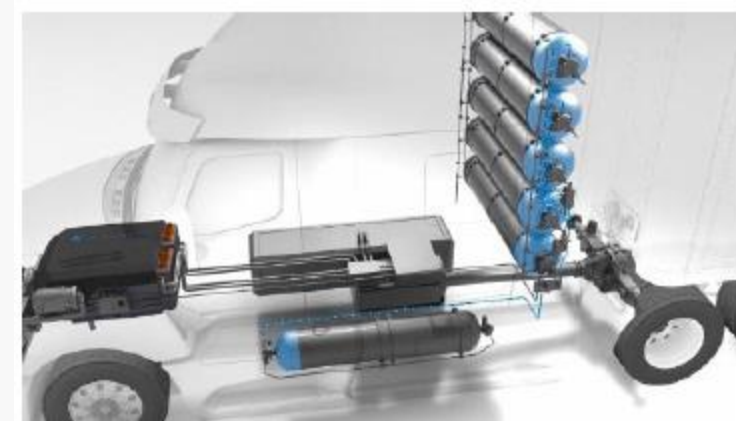

Transport for NSW (2023). Fuel cell electric vehicles (FCEV). Retrieved from:
<https://www.transport.nsw.gov.au/operations/freight-hub/towards-net-zero-emissions-freight-policy/knowledge-hub/fuel-cell-electric>

Safety Training for First Responders on ZEVs

Electric Vehicles

Energy System

High Voltage (Electrical) Systems

Electric Vehicle

Lithium Ion Battery

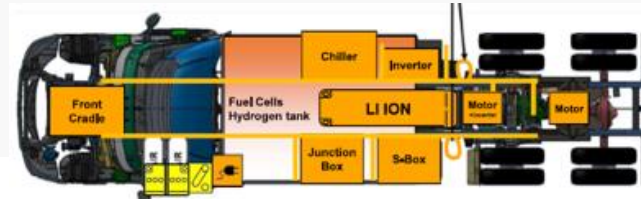

High Voltage / Orange Cables



DO NOT TOUCH

High Voltage (Electrical) Systems

Battery

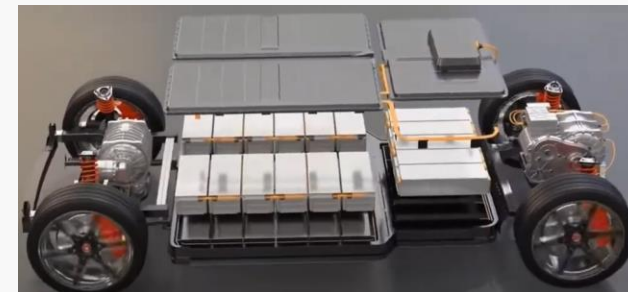
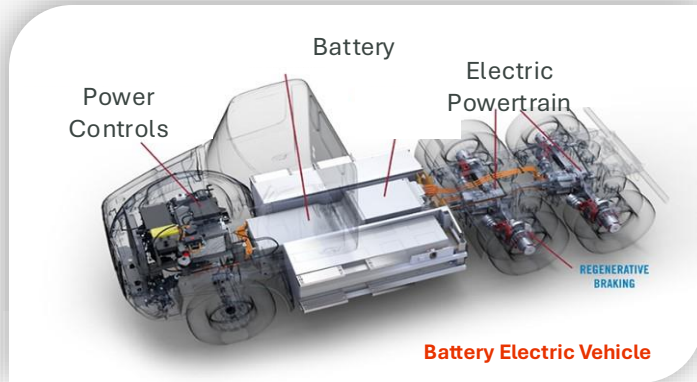

Battery is **structural**, built into the frame

Battery is the **central** portion of the vehicle

High Voltage (Electrical) Systems

Lithium-Ion Batteries

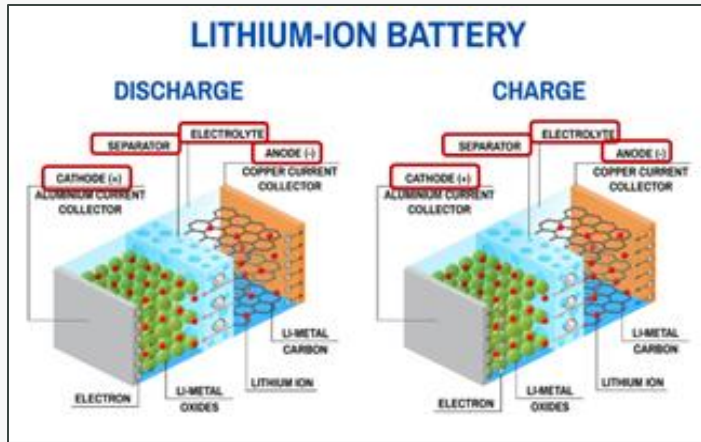

Cells

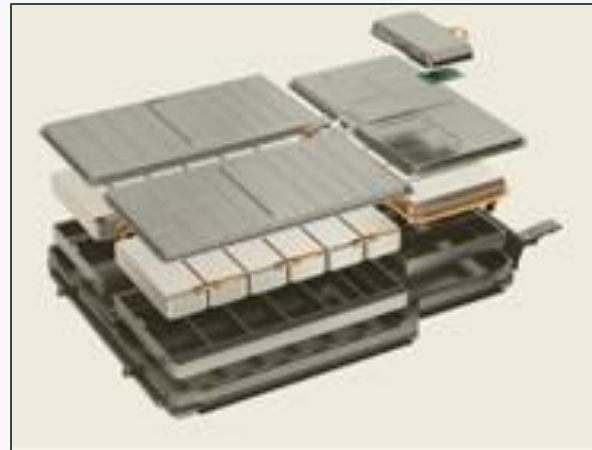

Parallel cells = Modules



Connected Modules

Lithium Ion Battery

Tesla Vehicle

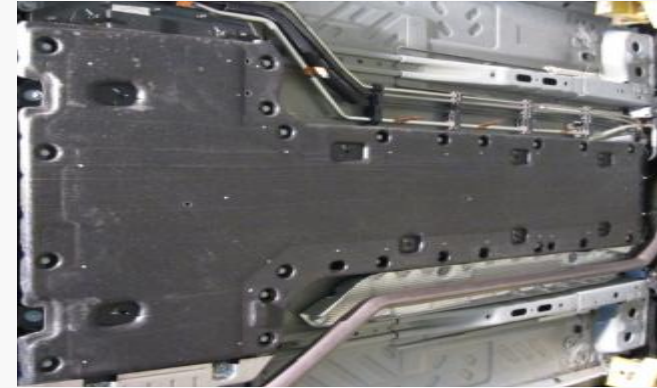

Battery Cell

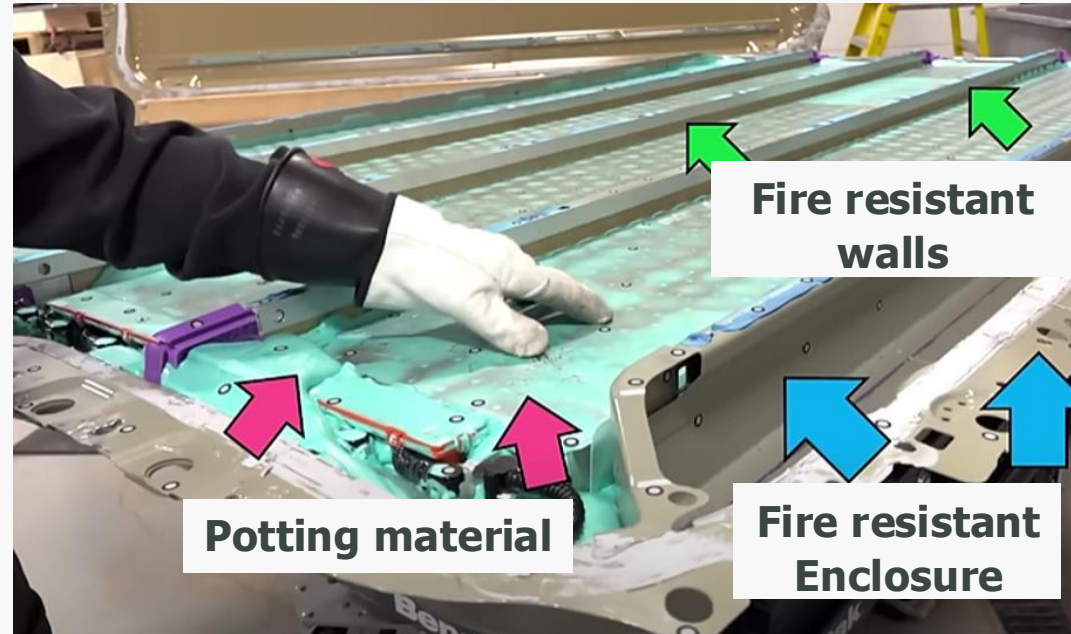

Connected Cells

Source: <https://www.youtube.com/watch?v=ERwGDtHUcyE>

Lithium Ion Battery

Tesla Vehicle

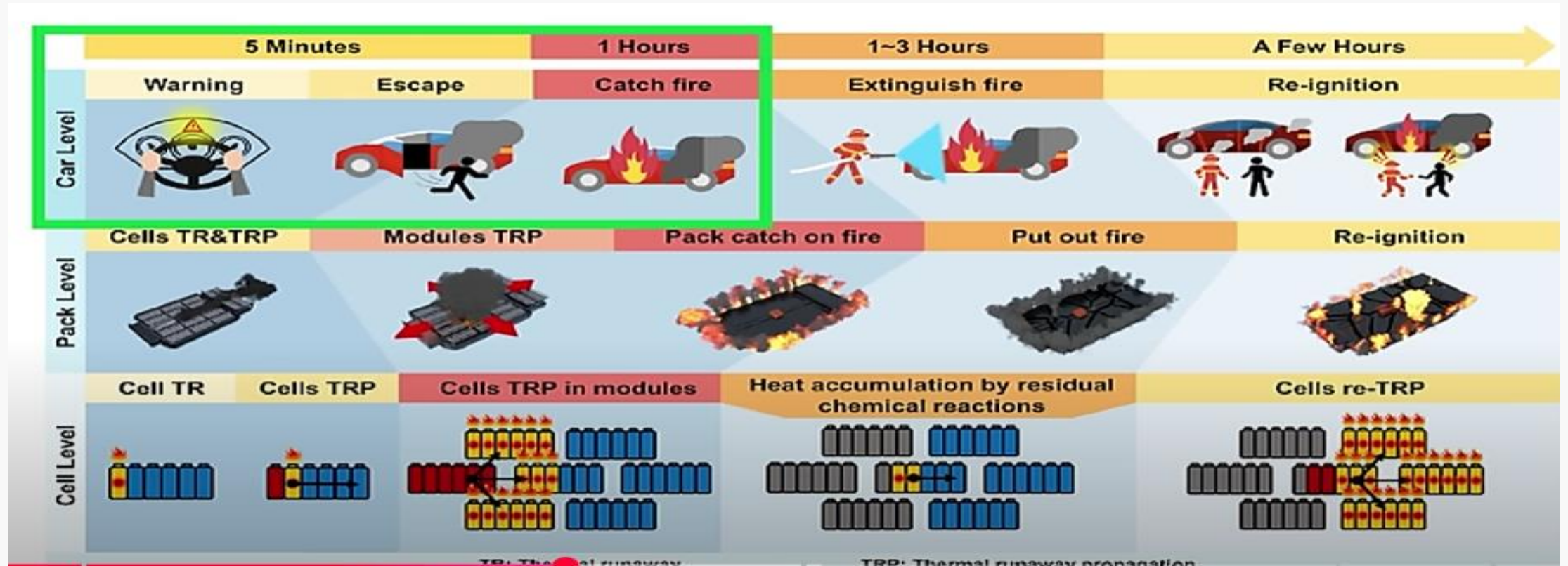

LEADING CAUSES OF EV BATTERY FIRE



The four leading causes of EV battery fire haven't changed in the past 12 months. They are:

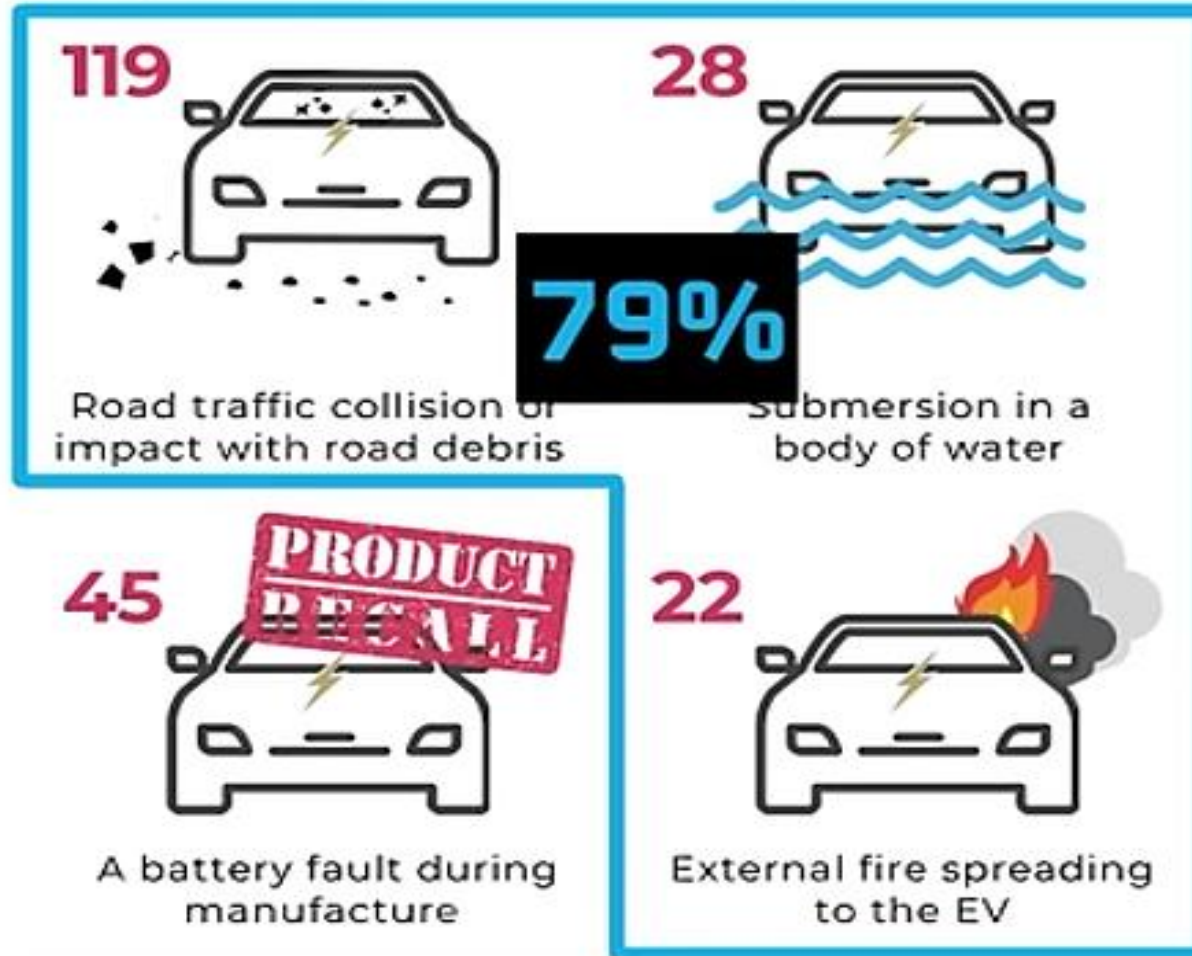

Road traffic collision or impact with road debris

Submersion in a body of water



A battery fault during manufacture



External fire spreading to the EV

51% of incidents have an **UNKNOWN** cause, primarily because it was not investigated

National Transportation Safety Board. 2020. Safety Risks to Emergency Responders from Lithium-Ion Battery Fires in Electric Vehicles. Safety Report NTSB/SR-20/01. Washington, DC.

High Voltage (Electrical) Systems

Thermal Runaway



Thermal Runaway

- A damaged battery can create more energy than can be removed.
- The battery's internal temperature increases beyond its ability to dissipate heat resulting in ignition.
- A chain reaction that can occur.

Indicators: smoke or hissing/popping sounds

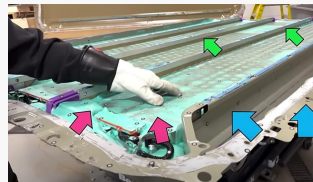

High Voltage (Electrical) Systems

Stranded Energy

2. Stranded Energy (Post Crash)

- Energy remaining inside a damaged or undamaged
- No effective way to remove/drain the battery
- Poses risks to first responders, passengers and bystanders

Fire

Shock Hazards

Thermal Runaway

Lithium Ion Battery

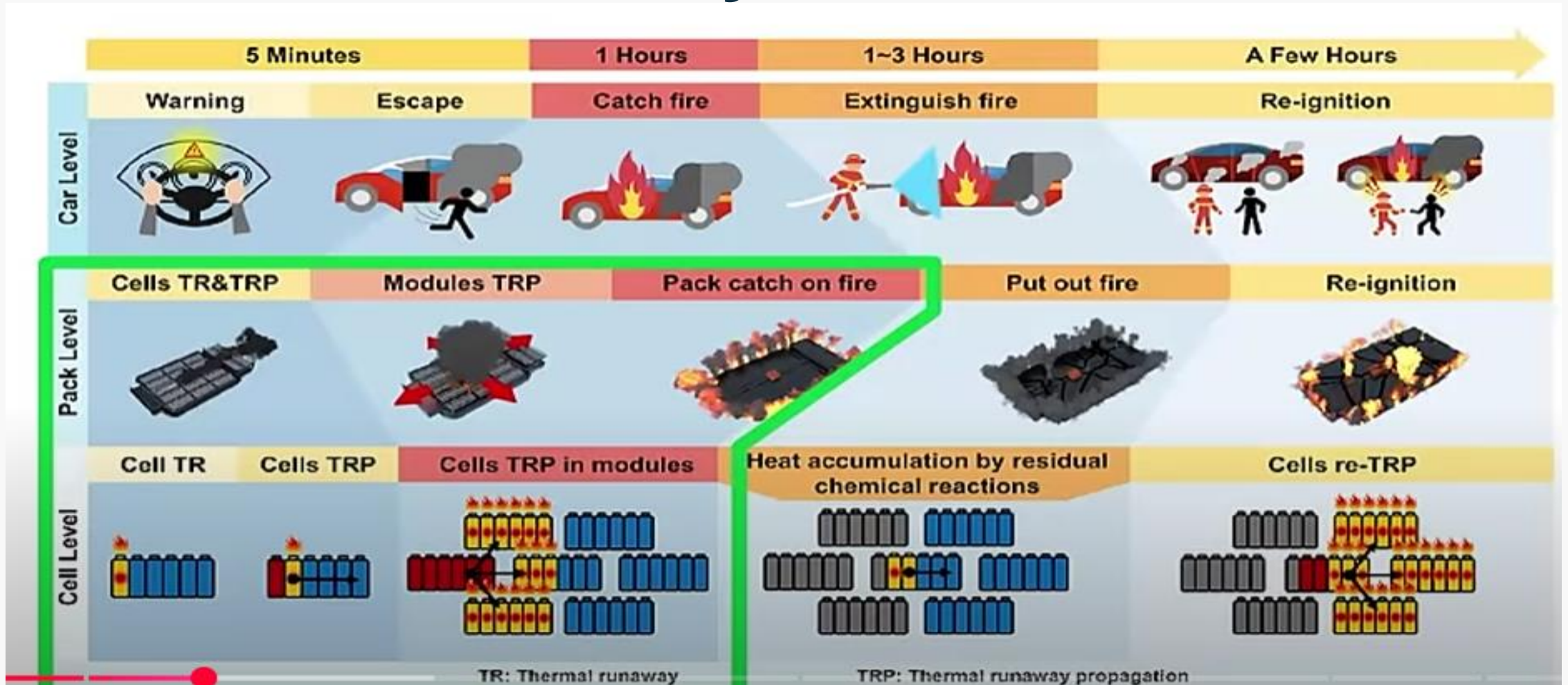

Safety Training for First Responders on ZEVs

Hydrogen Basics

Hydrogen

Properties

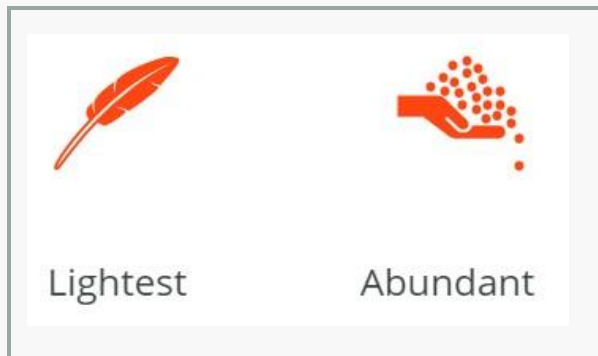

Energy dense

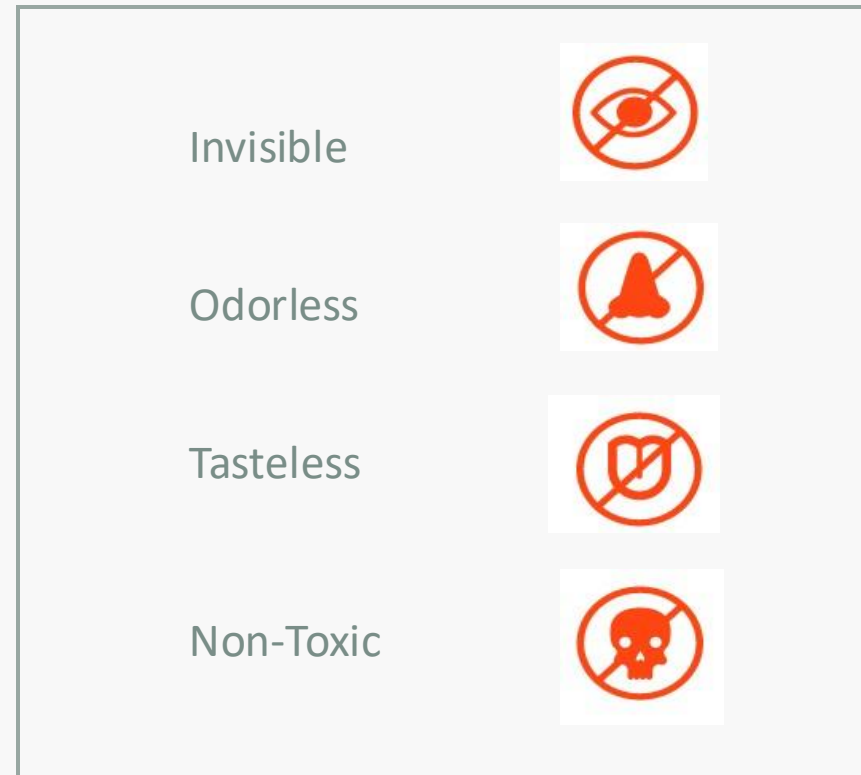

Hydrogen Safety

Leaks

Hydrogen leaks must be addressed promptly and with due care.

Do not store hydrogen vehicles indoors

Hydrogen leaks form the basis of all gaseous hydrogen hazards:

Flammability Hazards



Asphyxiation Hazards



Indoors

A hydrogen leak indoors

- collect on the ceilings and move towards the corners and lower level of the room
- increased risk of flammability and asphyxiation hazards



Outdoors

Hydrogen leak outdoors dilutes quickly into a non-flammable concentration.

- does not pool on the ground around the leak
- does not pollute the soil or ground water



Hydrogen Fires

Hydrogen Vehicle vs Conventional Vehicle Fire

Hydrogen Vehicle vs Conventional Vehicle Fire

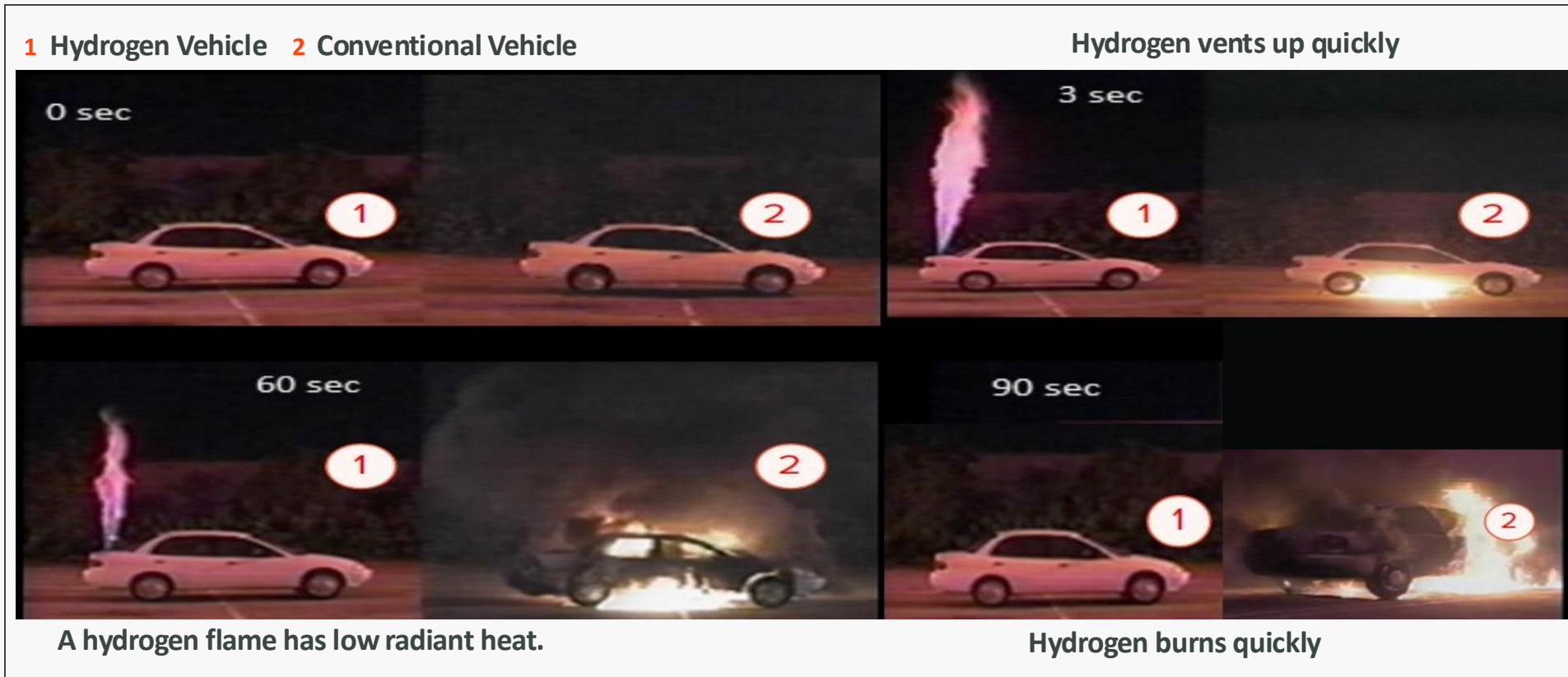

Hydrogen flames:

- **invisible** to the eye
- **low radiant heat**
- burns **quickly**

Component Level Safety

Tanks

- Thermal protective coating
30 minutes of heat resistance at 1000°C
- Thermal pressure release device (TPRD)
- Venting upwards

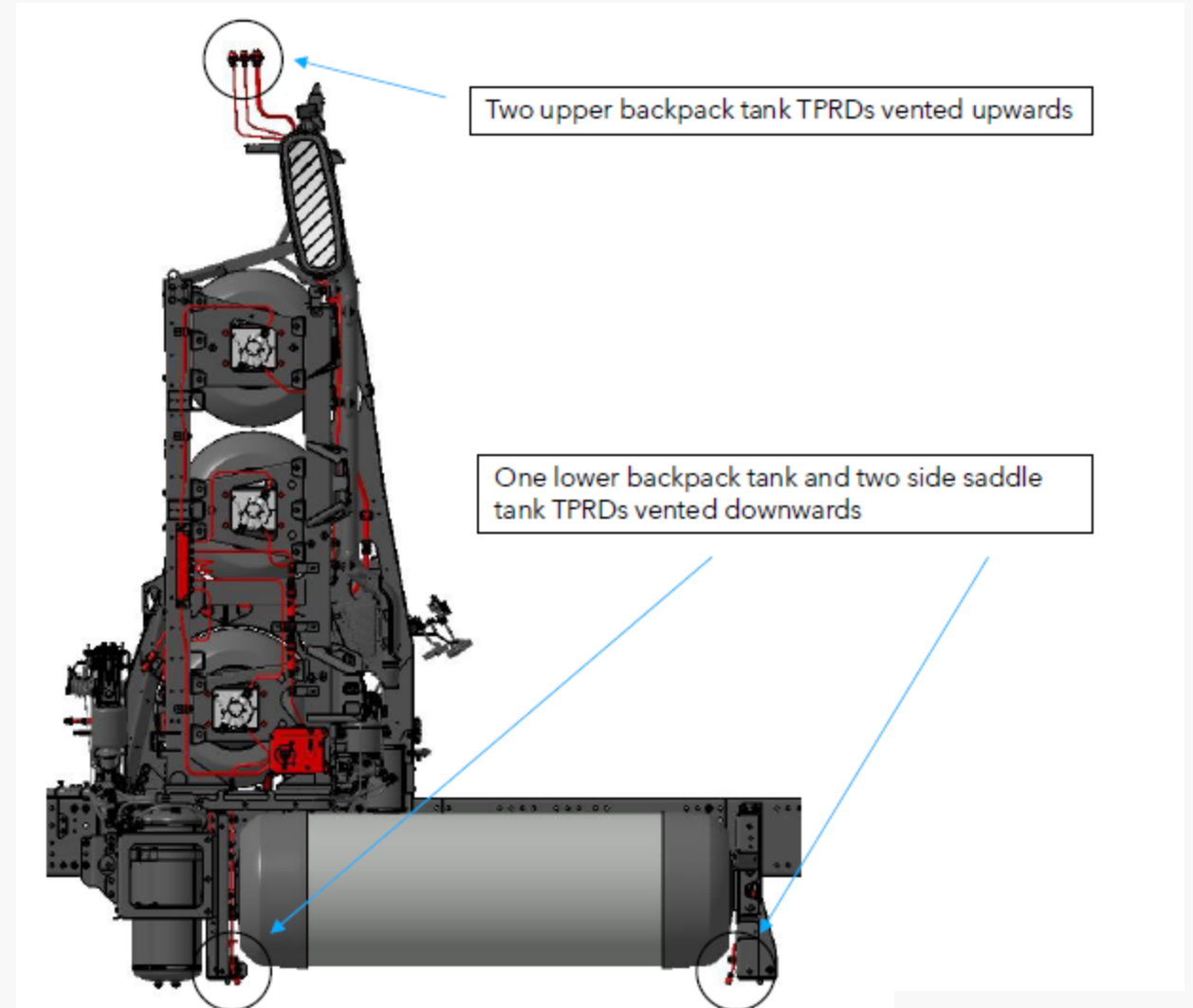

Hydrogen Equipment

Vehicles, Transport, Dispensing

- The hydrogen onboard our Class 8 trucks is gaseous.



Fuel Cell Electric Vehicle



Hydrogen Diesel Dual Fuel Vehicle



Hydrogen Diesel Dual Fuel Vehicle



Hydrogen Storage and Transport Trailer



Hydrogen Infrastructure

Safety Training for First Responders on ZEVs

Identification Emergency Response Guides

Volvo BEV

Identification

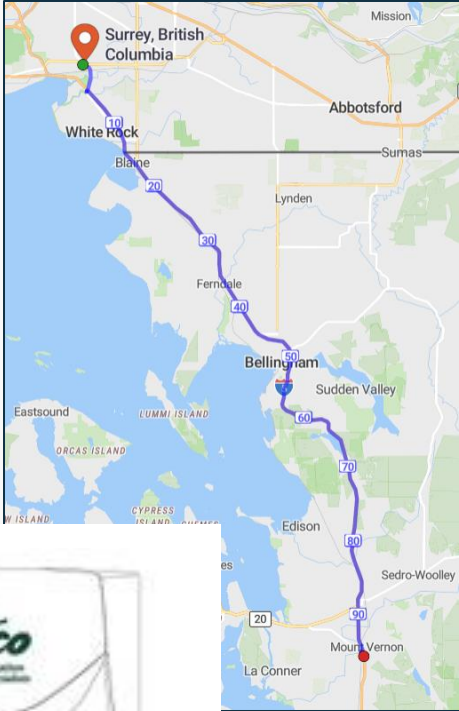

Zero Emission Vehicles

Emergency Response Guides

NFPA Emergency Response Guides

[https://www.nfpa.org/education-and-research/emergency-response/emergency-response-guides#aq=%40culture%3D%22en%22&cq=%40taglistingpage%3D%3D\(%22EV%20Guides%22\)%20%20&numberOfResults=12&sortCriteria=%40title%20ascending](https://www.nfpa.org/education-and-research/emergency-response/emergency-response-guides#aq=%40culture%3D%22en%22&cq=%40taglistingpage%3D%3D(%22EV%20Guides%22)%20%20&numberOfResults=12&sortCriteria=%40title%20ascending)

Volvo EV emergency response guide

[file:///C:/Users/Terri.Johnson/Downloads/Volvo%20VNR%20Electric%20\(1\).pdf](file:///C:/Users/Terri.Johnson/Downloads/Volvo%20VNR%20Electric%20(1).pdf)



Search...

EN

About NFPA ▾ For Professionals ▾ Education and Research ▾ News and Articles ▾ Membership ▾ Events ▾

EMERGENCY RESPONSE GUIDES

NFPA actively maintains a collection of Emergency Response Guides from alternative fuel vehicle manufacturers. These guides are free to download.

REFINE BY

Vehicle ... ^

- Acura (1)
- Alfa Romeo Tonale (1)
- Audi (1)
- Autocar (1)
- Automobili Pininfarina...
- Azure Dynamics...
- Battle Motors (1)
- Bentley (1)
- [+ Show mo...](#)

Results 1-12 of 79

Sort by: Title Ascending

Results per page: 12 24 48

TOPICS: EMERGENCY RESPONSE

Acura Emergency Response Guides

[View All](#)

TOPICS: EMERGENCY RESPONSE

Alfa Romeo Tonale Emergency Response Guides

[View All](#)

TOPICS: EMERGENCY RESPONSE









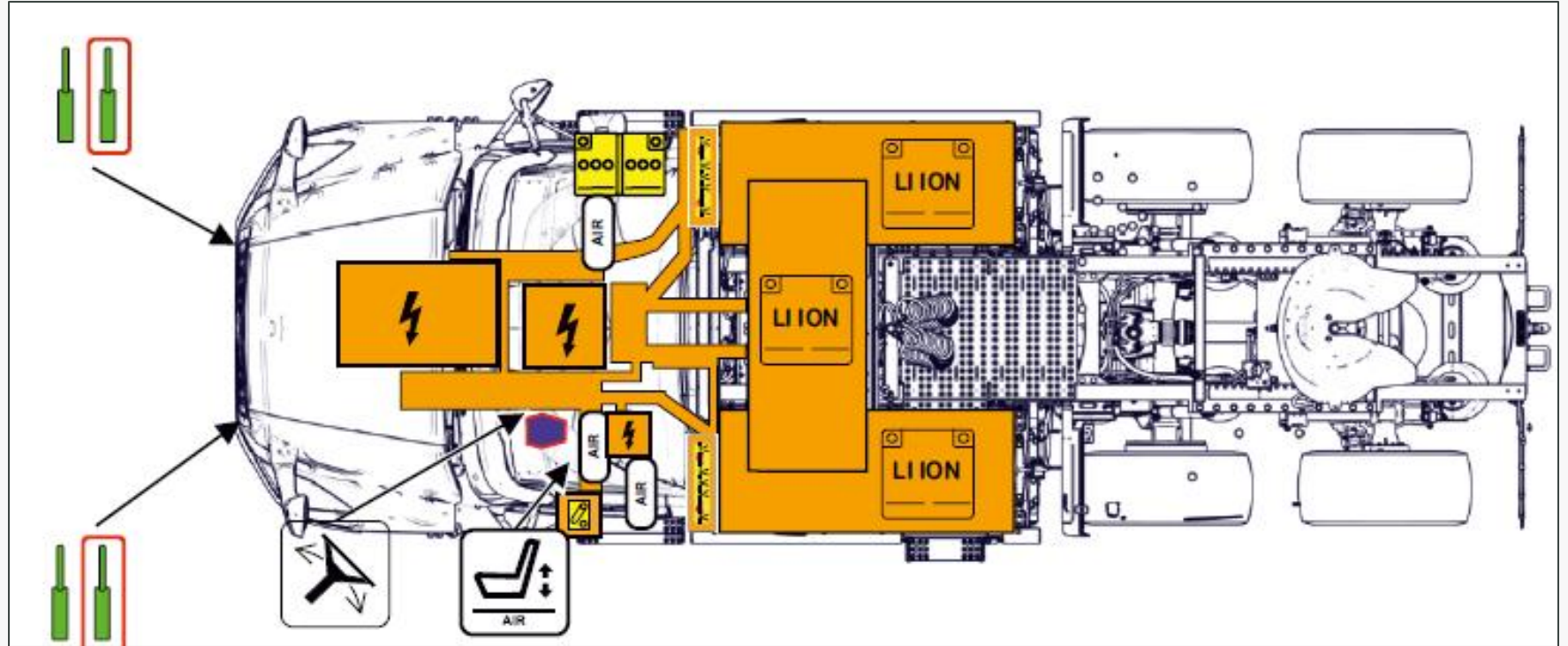



Audi Emergency Response Guides

[View All](#)

Volvo BEV

Emergency Response Guide

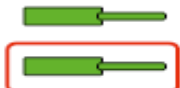

 High voltage lithium-ion battery	 Low voltage device that disconnects the high voltage	 Low voltage battery	 Air tank	 Seat adjustment	 Height control	 Cable to cut that disconnect high voltage components
 Steering wheel tilt control	 High voltage component	 High voltage cable	 Gas strut, pre-loaded spring	 Ignition key	 Airbag	

Volvo BEV

Emergency Response Guide



- Nearly silent operation
- Shut off vehicle

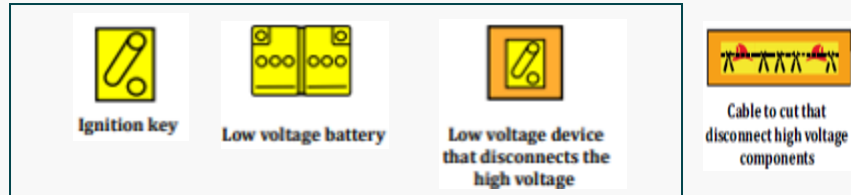

- Avoid interacting with high voltage systems

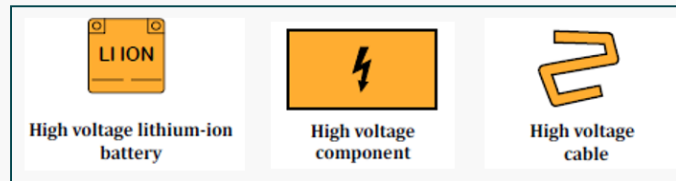

- Batteries may reignite

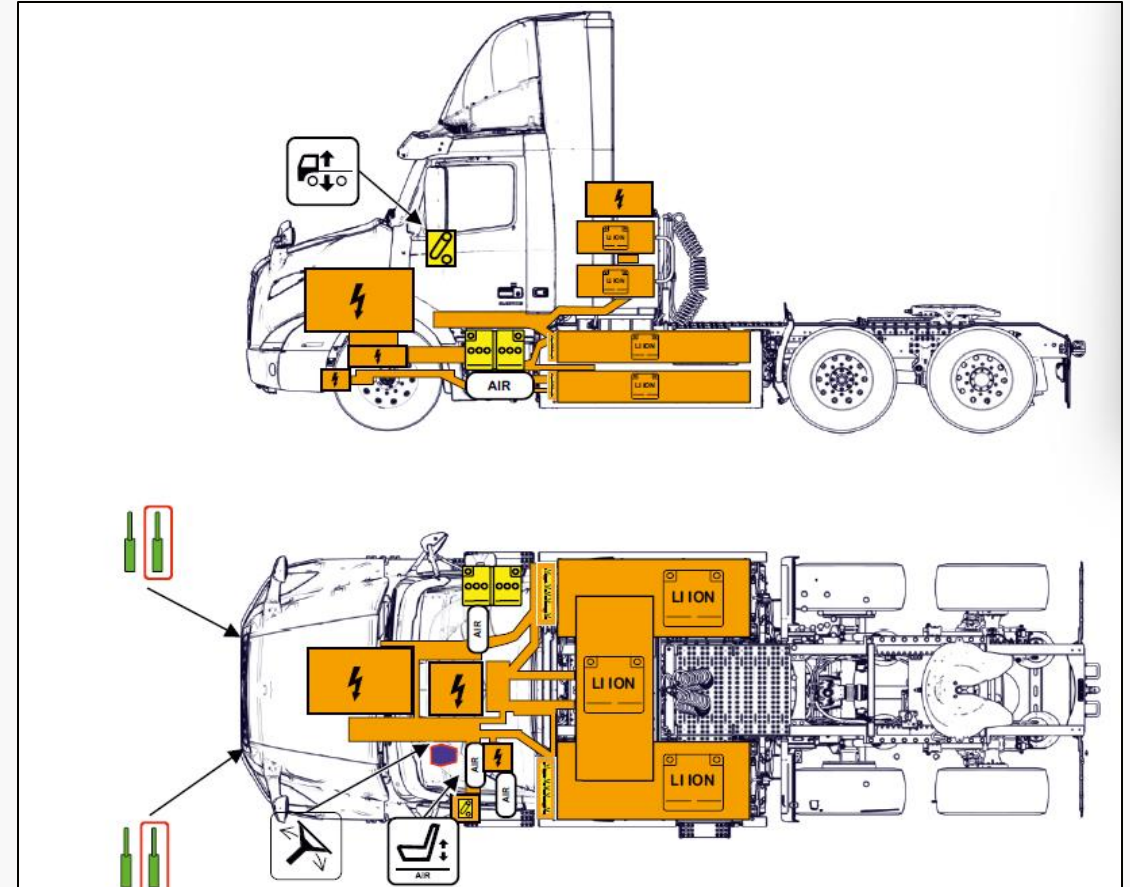

Battery Electric Vehicles

Emergency Response Guide

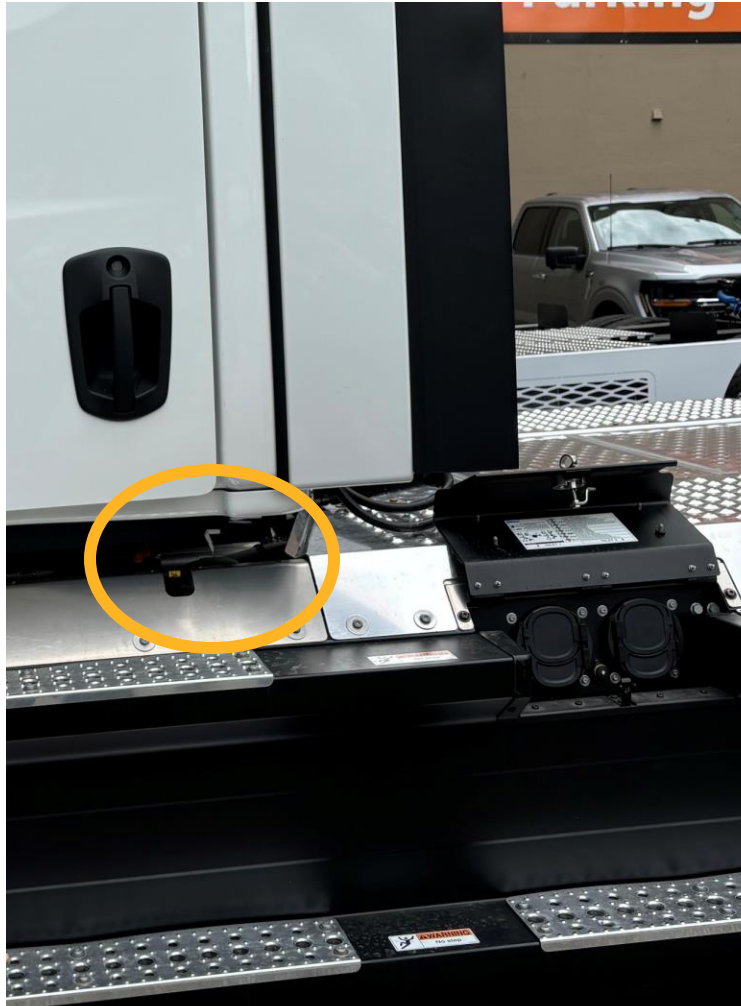

High voltage cut line

Volvo BEV

Emergency Response Guide



Guidelines for Fire Accident

The following guidelines are to be considered general recommendations in case of thermal incidents related to electric vehicles.

In specific cases other procedures may be more appropriate. Always follow local guidelines and regulations when dealing with thermal incidents.

In case of fires involving electric vehicles:

1. Alert nearby personnel and notify rescue services.
2. Prevent the fire from spreading to the traction batteries if possible. If not possible, evacuate the area.
3. Report the incident according to current reporting procedure.



In case of fire in the traction batteries:

1. Alert nearby personnel and notify rescue services.
2. Evacuate the area.
3. Report the incident according to current reporting procedure.



Safety Training for First Responders on ZEVs

First Response Zero Emission Vehicles

Electric Vehicles (EV)

First Response

- **Identify**
 - Electric motor, batteries (high voltage)
 - Hydrogen storage system (compressed gas)
- **Immobilize**
 - Approach from side (near silent operations)
- **Disable**
 - Auto disconnect (ignition)
 - High voltage shutdown/manual disconnect (manual service disconnect (MSD))
 - First Responder cut loop (isolate battery power)
 - * Will cause additional damage to the vehicle
- **Extrication**
- **Extinguishment**

High Voltage System

- Do not cut **orange** cables
- Do not touch **orange** cables without proper PPE

Off Gassing

- Full PPE with SCBA is required

Electric Vehicles (EV)

First Response

Battery Electric Vehicle (BEV) Fires

- Burn hotter than ICE
- Burn through energy slower than ICE
- Battery is the fuel
 - o Battery produces its own oxygen
- Remove the heat – cool it down
- Large, continuous and sustainable water supply
- BEV passenger vehicle: 3,000-8,000 gallons
- Reignition

Best Practices

Lithium-Ion Battery Fires



Not recommended for battery fires

- Class D fire extinguishers
- Firefighting foam
- Pancake nozzle (not enough water)
- Piercing nozzle (high voltage hazard)

Exposure control for battery fires

- Fire Blanket
 - limit vehicle fire
 - lower fire temperature
 - flammable gas release risk
- Copious amounts of water
 - water to cool battery
- Burry in sand



Let fire burnout (not ideal in many situations)



Lithium Ion Battery

Fire Blanket



Guidance for First Response

Vehicle Fire

Cool Battery

- Water Suppression, copious amounts of water
 - Apply water directly to the battery
- NOTE: **water cools** but will **not extinguish** a lithium-ion battery fire

Reignition

- Cool with water
- Bury in sand

Post Ignition Storage

- Always Tow a ZEV that has been involved in a vehicle fire
- Store at an isolated location



Fire Department Response to Electrical Vehicle Fires

Adapting our response plans through training, research, and experience is critical in the fire service. As sales of electric and hybrid vehicles increase, the fire service must continue to modify our tactics to properly respond and protect firefighters. Fighting vehicle fires is inherently dangerous. When responding to an electric or hybrid vehicle fire there are additional challenges responding crews must consider.

Additional response-specific information can be found on most automobile manufacture web pages. [NFPA Quick Vehicle Response Guide](#)

Pre-Incident

Modify or establish your department policy or standard response guideline to vehicle fires and ensure it includes practices for electrical vehicle fires. Include guidelines for limited interaction and when crews should allow the vehicle to burn.

When working on roadways, protect the work area per department policy. Staff should consider that this may include a vehicle fire or extrication. Staff operating on roadways should anticipate possibly longer time frames to manage/control EV vehicle fires and maintain heightened situational awareness.

NFPA has a full series of documents on various EV safety response (including emergency response guides by manufacturer).

Review response and post incident procedures with law enforcement and towing companies.

Batteries that have been or are suspected of damage or otherwise compromised, but have not caught fire, need to be monitored for thermal runaway.

Train on department policy and perform practical scenarios which support the response plan.



INCIDENTACTIONS

When arriving on scene, the first arriving company should perform a proper size up. This includes the extent of the fire and if it is a compartment fire or includes the electric components of the car. Similar to other vehicle fires, is the engine compartment or the passenger compartment on fire? The best method for managing or controlling a battery fire is with water. Battery fires will initially show from under the vehicle.

- Protect your work area through established department policy and establish tactical priorities (fire, extrication, victim care) and ensure the vehicle is in park and off, if possible.
Wear full PPE with SCBA with face-piece and establish an appropriate command structure.
Consideration and tactics may be categorized in offensive or defensive mode. This may be based on exposures and the extent of fire which may include actions to let the vehicle burn. Use a thermal imaging camera to help with the 360 size-up.
Secure a large, continuous and sustainable water supply from one or more fire hydrants or multiple water tenders (3,000-8,000 gallons).
Where safe, consider chocking the wheels. EVs move silently; so never assume it is powered off. Never assume that an EV will not move.
Extinguish small fires that do not involve the high voltage battery using typical vehicle firefighting procedures.
When attacking the vehicle fire, understanding that once the contents of the fire are extinguished, sustained suppression on the battery pack may be necessary. Use a large volume of water such as multiple 1 3/4-inch hand-lines to suppress and cool the fire and the battery. Put water on the burning surfaces.
Have sufficient fire personnel and apparatus on scene for an extended operation to monitor the battery's heat or possible secondary ignition. The heat from the fire may have damaged additional cells, which may require additional suppression activities.
Batteries should always be treated as energized. During overhaul do not make contact with any high voltage components.

Post Incident

Brief the towing company and their personnel on the hazards, including providing 50' clear space around the vehicle once stored and never inside a building. An engine company may need to escort the vehicle to the recovery location.

Batteries should always be treated as energized and pose an ongoing risk to the investigator. Follow NFPA 921 protocol for vehicle safety during post-response investigation, arson investigation, and vehicle investigation.

Thermal events with the battery system could continue for some time after the initial incident. Establish response protocol for secondary fires.

International Association of Fire Chiefs, 4795 Meadow Wood Lane Suite 100W, Chantilly, VA 20151



GENERAL PROCEDURES FOR HYBRID AND ELECTRIC VEHICLE FIRE SUPPRESSION

GENERAL

- Use standard vehicle firefighting equipment and tactics in accordance with department SOPs/SOGs.
Hybrid and electric vehicles do not require special equipment for fire suppression/extinguishment.



Use Full PPE and SCBA

PERSONAL PROTECTIVE EQUIPMENT

- All personnel should wear and utilize full PPE and SCBA as required at all vehicle fires.

EXTINGUISHING AGENTS

- Use water or other standard agents for vehicle fires.
The use of water does not present an electrical hazard to firefighting personnel.
If an HV battery catches fire, it will require a large, sustained volume of water.



Safe to Use Water

WARNINGS

- If using water to extinguish/suppress a high voltage battery, use a large volume of water. Using only a small amount could allow dangerous toxic gases to be released.
If a Lithium Ion (Li-Ion) HV battery is involved in a fire, there is a possibility that it could reignite after extinguishment. If available, use thermal imaging to monitor the battery. Do not store a vehicle containing a damaged or burned Li-Ion HV battery in or within 50 feet of a structure or other vehicle until the battery can be discharged.

NOTE:

Because high voltage batteries are in protective cases, it is very difficult to get any extinguishing agent directly onto the burning cells. The application of large volumes of water may cool the high voltage battery sufficiently to prevent the propagation of fire to adjacent cells.

FIRE

Guidance for First Response

Vehicle Fire

Battery not Involved:

- Respond as in any other vehicle fire

Chock Wheels

- Silent operations

Reference NFPA Emergency Response Guide

- Shut offs
- Disabling vehicle circuits

Establish Water Source

- Additional engines requested
- Water shuttle operation

PPE

- Respiratory hazards, SCBA required
- Prolonged time: Be prepared to exchange SCBA cylinders

High Voltage

- Avoid contact with components and cables
- Identify high voltage battery placement
- Apply water even after flame is extinguished

Vehicle Removal

- Monitor battery for hissing/popping/smoke
- Thermal imaging camera may indicate heat profile
- Tow truck removal
- Stored isolated region

Review

EV Fire Safe



Safety Training for First Responders on ZEVs

Risks

Electrical Vehicle Fires

Risks

Zero Emission Vehicles

1. **Stranded Energy**
 2. **Thermal Runaway**
 3. **Battery Reignition**
- **Silent Operations**
 - **Electrical Hazards: High Voltage System**
 - **Respiratory Hazards: Vapor Cloud Explosions**
 - **Use only Water**
 - Water flow calculations
 - Longer time to suppress
 - Larger water volumes
 - **Isolated Storage**

Risks

Electric Vehicle Fires

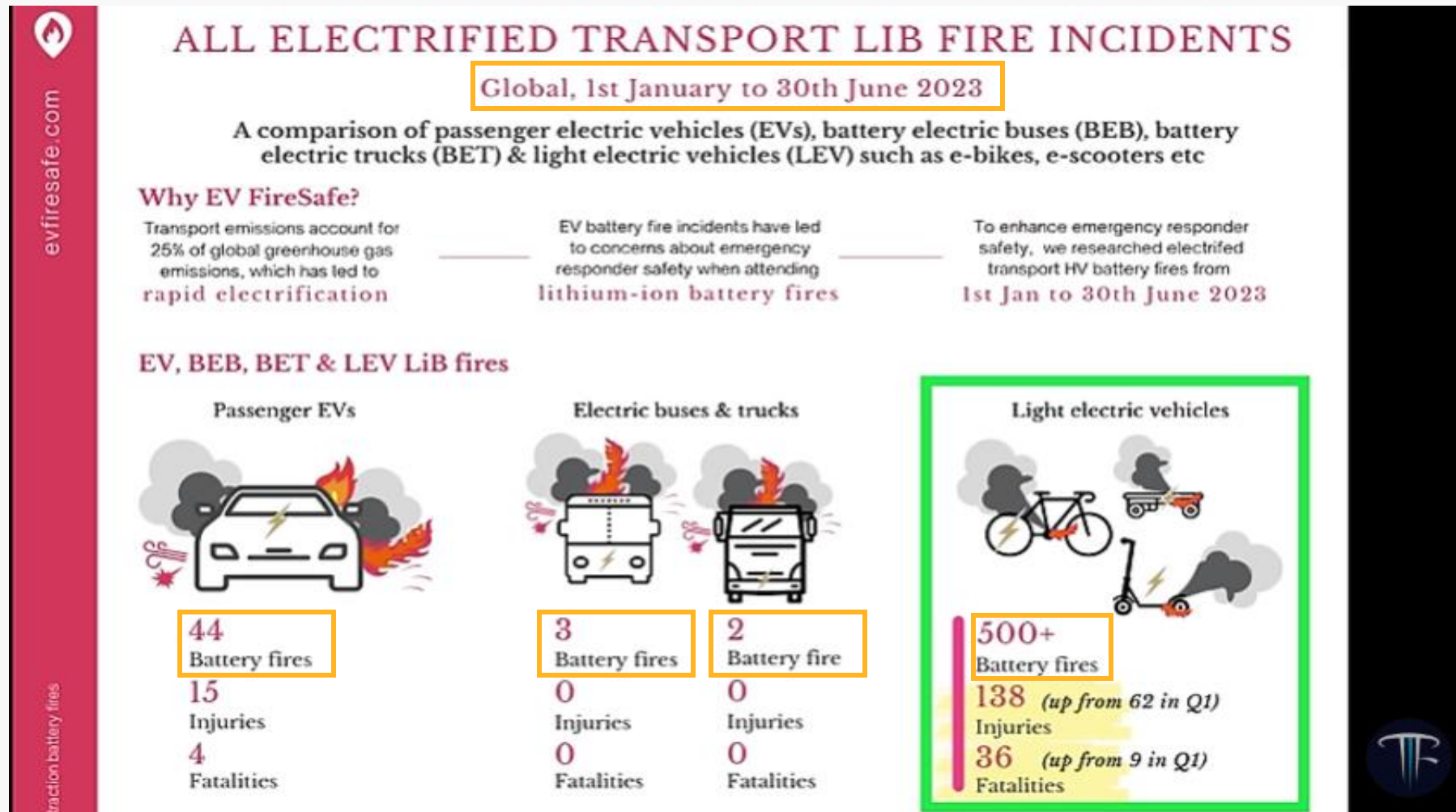

Safety Training for First Responders on ZEVs

Resources

Additional Resources

NFPA Emergency Response Guide:

<https://www.iafc.org/topics-and-tools/resources/resource/emergency-response-guides>

Emergency Response Guides for
electrical vehicles



Additional Resources

Courses

- NFPA: <https://www.nfpa.org/for-professionals/training-for-me/buy-alternative-fuel-vehicles-training/electric-vehicles>
- Canadian Association of Fire Chiefs: <https://cafc.ca/page/green-technology>
- SAE Hybrid and EV first responder Recommended Practices: https://www.sae.org/standards/content/j2990_201907/
- Intro Hydrogen Vehicles, First Responders: <https://www.aiche.org/ili/academy/courses/ela253/introduction-hydrogen-safety-first-responders>
- First Response Hydrogen Vehicles: <https://www.aiche.org/ili/academy/courses/ela262/fire-response-extrication-hydrogen-fuel-cell-vehicle>
- Firehouse Training: <https://ffao.on.ca/2024/06/16/electric-vehicle-lithium-ion-battery-training/>
- High Voltage Safety Training: <https://energysecurityagency.com/imi-courses/>
- Electric Vehicle Safety for First Responders: <https://teex.org/class/cef102/>

Additional Resources

Videos

- NFPA: Source: <https://www.nfpa.org/for-professionals/training-for-me/buy-alternative-fuel-vehicles-training/Electric-Vehicles> (Preview EV Safety Training: embedded on page mid way down)
- National Transportation Safety Board: Source: <https://www.youtube.com/watch?v=J6eS6JzBn0k>
- Monroe Fire Department: Source: <https://www.youtube.com/watch?v=GtD5dn5CpzI>
- Isolating the High Voltage Battery: Source: <https://www.youtube.com/watch?v=2LBPuFbmoJk>

Additional Resources

Academic Papers

- National Transportation Safety Board. 2020. Safety Risks to Emergency Responders from Lithium-Ion Battery Fires in Electric Vehicles. Safety Report NTSB/SR-20/01. Washington, DC.
- Canadian Association of Fire Chiefs. 2024. Medium and Heavy Duty Zero Emission Vehicles: Assessment of Information available for the Fire Training Service. Source: https://cdn.ymaws.com/cafc.ca/resource/resmgr/mhdev_report/ENG-MHDZEV_Report_Final.pdf
- Long, T.R., Blum, A.F., Bress, T.J., and Cotts, B.R.T. “Best Practices for Emergency Response to Incidents Involving Electric Vehicles Battery Hazards” Fire Protection Research Foundation. June 2023. Source: https://www.energy.gov/sites/prod/files/2014/02/f8/final_report_nfpa.pdf
- Kang, S., Kwon, M., Choi, J.Y., and Choi, S. “Full Scale Fire Testing of Battery Electric Vehicles” Applied Energy, February 2023. Source: <https://www.sciencedirect.com/science/article/pii/S0306261922017548>

Follow up Survey

<https://form.jotform.com/250496215715054>



Did you find this information session valuable?

- Yes
- No

What information was most useful to you?

What would you like included in future presentations?

Submit

THE VOICE THE STANDARD THE RESOURCE

Thank you for attending

Suncor, **For additional information please contact:**
Terri.Johnson@AMTA.ca

February 2025

Zero Emissions Vehicles and Fueling Infrastructure

Identification Emergency Response Guides

Zero-Emission Vehicles

Battery Electric Vehicle (BEV)



Fuel Cell Electric Vehicle (FCEV)



AZETEC FCEV



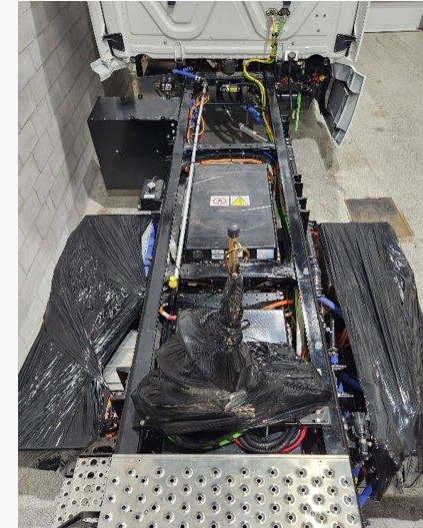



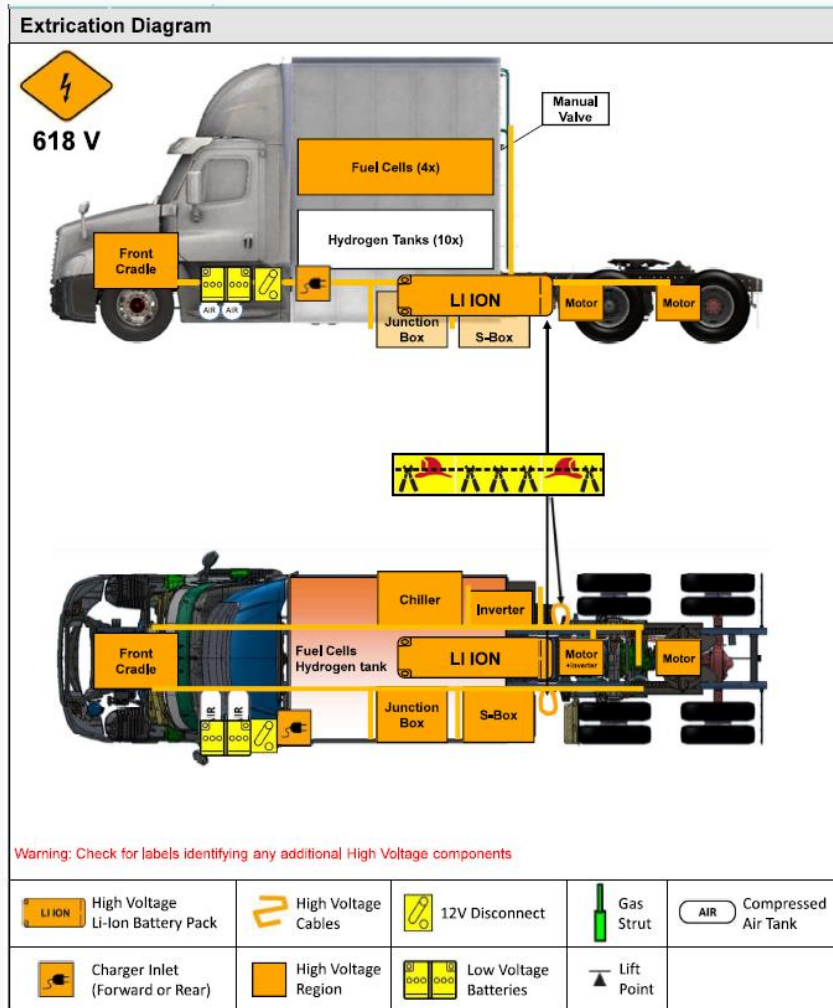

Emergency Response



AZETEC FCEV







Emergency Reposnse Guide







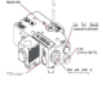
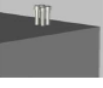







		Warning TBD
	Master Disconnect Switches	Location: Motor Bay Area
	Pulling the Emergency Master Disconnect Switches will disconnect all 12/24VDC in the vehicle	
		
	OFF	ON
Safety features – High Voltage		
	Using HV safety devices will immediately cut power to concerned devices which may damage the system components. Those devices are to be used for emergency only.	
	Cut Loop	Location: In front of first rear wheels on both sides
	The cut loop is cut to disable the complete vehicle electric system	
	Manual Service Disconnect	Location: S-Box
	The S-Box Manual Service Disconnect can be removed to disconnect High Voltage of the battery to the rest of the vehicle. <ul style="list-style-type: none"> Removing the S-Box MSD doesn't cut the HREX power Power is still live between batteries and the S-Box as long as battery MSD are not removed 	
	Manual Service Disconnect	Location: Batteries
	Each battery have a Manual Service Disconnect that can be removed to disconnect the element from vehicle electric circuit. The batteries MSD are bolted in place and accessible via trap doors at the bottom of battery cradle (tool required to access)	
	Torque Removal Button	Location: Driver dashboard
	The Emergency push button will disable the Hydrogen and propulsion systems. The Battery is still active to maintain power steering and air brakes	

AZETEC FCEV

















Emergency Response Guide

	<p>The Isolation Monitoring circuit is constantly measuring the isolation resistance in the HV electric circuit. If a loss of isolation is detected, the system will react to secure the vehicle</p> <p>Stage 1: <250 ohms/volts fault: Fault raised to the driver's HMI</p> <p>Stage 2: <100 ohms/volts: Red telltales on HMI. Subsequent startup prevented.</p> <p>➤ Will require maintenance personal to reset the situation</p>	
Safety features – Hydrogen		
	<p>Warning TBD</p> <p>Vehicle's Hydrogen shall always be purged down to 10% of the ignition concentration in the air (4%) before being stored inside a building</p>	
	<p>Hydrogen venting pipes</p>	<p>Location: Top of the HREX in the rear-Passenger corner and front passenger corner</p>
	<p>The Hydrogen venting pipes allows Hydrogen dispersal in the event of a pressure release or a TPRD release. These conduits must never be obstructed</p> <ul style="list-style-type: none"> The pipes are terminated with a cap that pops out when the venting pipes are used 	
	<p>Manual Shut Off Valve</p>	<p>Location: Back of the HREX</p>
	<p>The Manual Shut Off Valve allows one to cut the Hydrogen supply from the tanks to the Fuel cells. During an incident, if safe to do so, the valve should be closed. It is located at the back of the HREX behind the fuel control panel door.</p>	
	<p>Thermal Pressure Relief Device (TPRD)</p>	<p>Location: H2 tanks</p>
	<p>Thermal Pressure Relief Device glass component will break and release H2 via the H2 venting pipes if high temperature are reached around the H2 tanks</p>	
	<p>Pressure Relief Valve (PRV)</p>	<p>Location: TBD</p>
	<p>If the Hydrogen circuit is over-pressurized, the Pressure Relief Valve (PRV) will safely relieve the exceeding pressure through the H2 venting pipes at the top of the HREX.</p>	
	<p>Hydrogen Sensors</p>	<p>Location: 2 in the roof of the HREX, 4 in the fuel cells (1 per fuel cell)</p>
	<p>A hydrogen sensor detects the presence of hydrogen gas. They are utilized in the HREX system to detect if a leak has occurred in the system. If the hydrogen leak occurs and is detected, then the system will have to safely shutdown.</p>	

	<p>Warning: Keep all lift equipment at least 12 inches (30 cm) from all high voltage components.</p>	
	<p>Warning: This vehicle lacks an internal combustion engine. Silent movement capability exists until all steps in Section 3 are completed. Complete Section 3 steps if possible before immobilization.</p>	
	<p>Blocking Wheels</p>	<p>Block all wheels.</p>
	<p>Lifting Truck (with Jack)</p>	<p>Only use the lift points identified in the extrication diagram with this icon for jacks.</p>
3. Disable Direct Hazards / Safety Regulations		
	<p>Warning: Assume all high voltage components are always energized. Do not cut any High Voltage components, including high voltage orange cables.</p>	
	<p>Warning: Cables between the high voltage battery and the S-box remain energized after the vehicle disable steps (including the 2 minutes wait) are completed.</p>	
	<p>In case of emergency actions on the vehicle:</p> <p>Cut a 2-inch (5 cm) segment (2 cuts) from red cut loop. All wires are bundled in cut loop identified in Extrication Diagram.</p>	
	<p>Wait 4 Minutes for High Voltage Capacitors to Discharge.</p>	
	<p>Normal operation truck shutdown method</p> <p>Step 1: Unplug the Charger Cable or Remove Power from the Charger.</p>	
	<p>Step 2: Remove the Key from Ignition.</p>	
	<p>Step 3: Engage parking brakes.</p>	
	<p>Step 4: (Primary Step): Turn 12V and 24V Disconnect Counterclockwise to OFF Position.</p>	

AZETEC FCEV

Emergency Response Guide

				
	High Voltage (618 V)	Corrosives	Flammable	Health Hazards
5. Fire				
<p> Warning: Always wear full fire fighter PPE (turnout gear), including a positive pressure self-contained breathing apparatus.</p> <p> Warning: Treat fires involving charging stations as energized fires until power to the charger can be shut down.</p>				
	Use Water to Extinguish Li-ion Fires		Do Not Use Wet Foam	
	Hazardous to Human Health: <ul style="list-style-type: none"> • May cause an allergic skin reaction • Do not breathe dust, fumes, gas, mist, vapors, or spray. 		Flammable Components	
	Explosion Hazard: <ul style="list-style-type: none"> • Explosive gas could accumulate. • Move truck outside building after extinguishing fire 		Corrosives: <ul style="list-style-type: none"> • Causes skin burns and eye damage 	
	High Voltage (650 V): <ul style="list-style-type: none"> • CAT III (1000 V) rated gloves required for exposed HV parts 		Check Li-ion Battery Pack for Fires with Thermal Infrared Camera (TIC or IR Gun)	
6. Water Submersion				
	<ul style="list-style-type: none"> • If High Voltage part damage exists (hissing, crackling, bubbles, exposed cables, etc.), call DANA Customer Center for guidance. • If no High Voltage part damage exists; remove the truck from the water; let the water drain; follow Section 3 (Disable Direct Hazards); and do not attempt to drive. 			
7. Towing / Transportation / Storage				
	<ul style="list-style-type: none"> • Follow Section 3 (Disable Direct Hazards). • Tow vehicle from the front axle. <ul style="list-style-type: none"> • Remove the axle shafts to tow from the front (propulsion motor not spinning), cage front drive axle Diff Lock and brakes. • [Emergency] If the truck must be moved to the side of the road AND no high voltage damage is present, it can be moved at less than 16 kph. • Store outdoors, 50 feet away from other equipment/structures, and routinely check the battery pack for high temperatures with a Thermal Imaging Camera (TIC or IR Gun). 			

Nikola FCEV

Emergency Response Guide

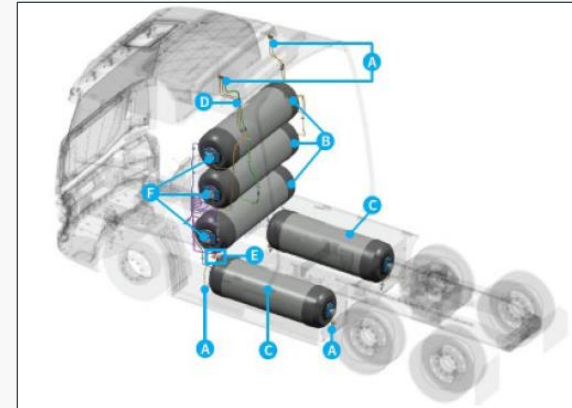

Nikola FCEV

Emergency Response Guide

NIKOLA®

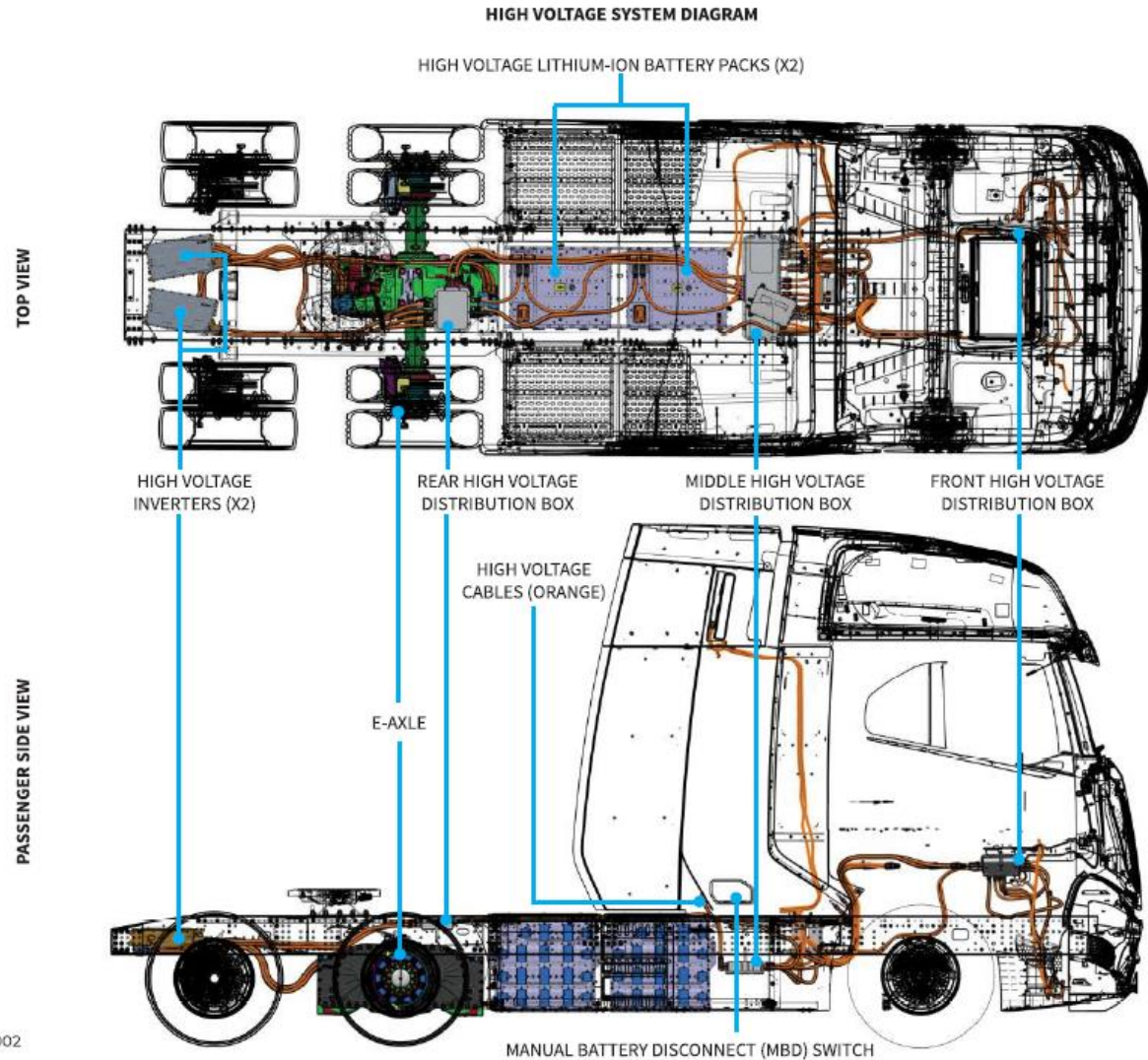

PEHS-MAN-0002
Rev 0

Nikola FCEV

Emergency Response Guide

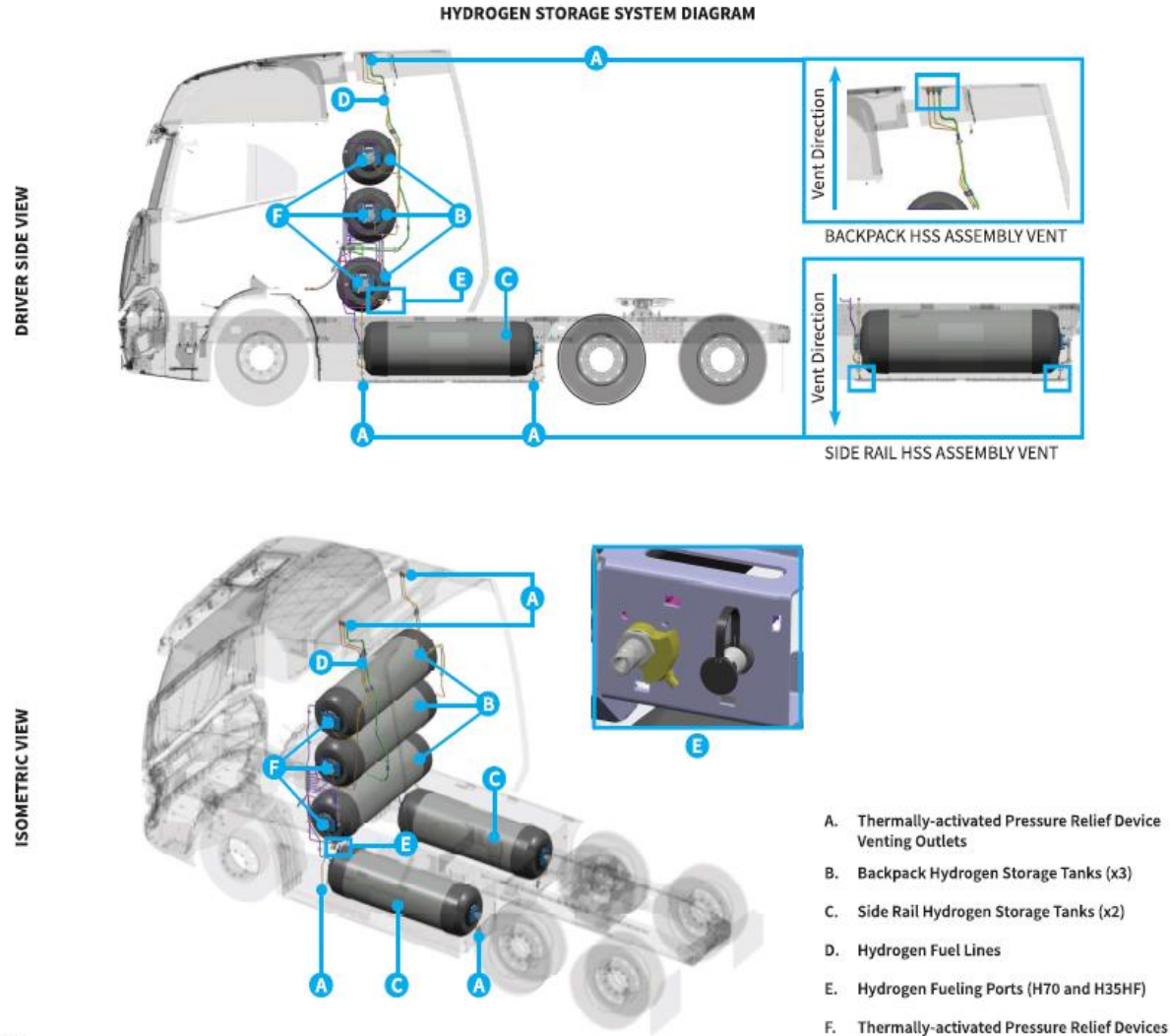

Nikola FCEV

Emergency Response Guide

NIKOLA

EMERGENCY FIELD GUIDE NIKOLA CLASS 8 TRUCK

04/20/2023

Figure 3: Emergency shutdown procedure.

Disabling High Voltage (HV):



- Locate the Manual Battery Disconnect (MBD) access door on the passenger side of the vehicle. Lift the latch and rotate to open the access door.
- Locate the MBD switch
- Turn the MBD switch counterclockwise (CCW) to off
- Wait a minimum of 5 minutes for the high voltage system to de-energize

MBD ON



MBD OFF



WARNING

It is possible for the HV system to keep significant levels of voltage for a short duration after the system has been deactivated. Allow 5 minutes for voltage to de-energize before interacting directly with HV components.

Do not touch, cut, or open high-voltage components and/or high-voltage batteries.

Always wear full firefighting and proper Insulated electrical PPE (safety glasses, gloves rated for at least 1,000V, HV insulated safety shoes, etc.). Remove all metallic jewelry including rings, chains, and watches.

- Do not lift or jack up this vehicle for any reason unless there is a person trapped underneath it. If so, lift only by designated LIFT POINTS.

EMERGENCY FIELD GUIDE NIKOLA CLASS 8 TRUCK

Lifting Points:

The Vehicle can be lifted/jacked at the points along each axle shown in the figure below.

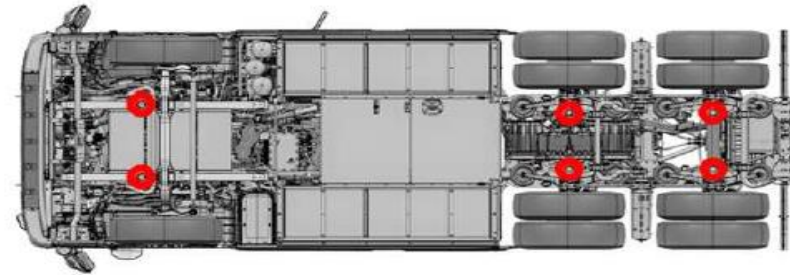

WARNING

Never stabilize or lift the vehicle directly from the battery pack or anywhere along the high voltage system.

Figure 5: Stored energy warning.

	 	800V
	 	12V and 24V
	 	Refrigerant (R134A) Coolant
	 	Compressed Hydrogen



WARNING

If coolant and/or refrigerant escapes from the system, there is a risk of thermal reaction within the high voltage battery system.

Monitor temperature of the high voltage battery for thermal reaction.

Nikola FCEV

Emergency Response Guide



TRE FCEV FUEL CELL ELECTRIC TRUCK | **FIRST RESPONDER SAFETY SHEET**

01 IDENTIFY NIKOLA ELECTRIC VEHICLE



CAUTION

- High voltage is still present in both lithium-ion battery packs even after the high voltage is disabled.
- Assume high voltage components are energized. Do not touch, cut, or open high-voltage (orange) cables, components, or high-voltage batteries. See the high voltage diagram on the reverse page.
- The electric motor is silent. Lack of noise does not signify the vehicle is turned OFF. Movement or restart capability exists until the vehicle is fully shut down.
- Avoid toxic fumes produced during lithium-ion battery fires.
- If the hydrogen is on fire, extinguishing the hydrogen flame completely may cause unburned hydrogen to accumulate and lead to a secondary explosion. Allow the hydrogen to dissipate completely.
- If fire has reached the Compressed Hydrogen Storage System, DO NOT SPRAY WATER ON THE COMPRESSED HYDROGEN STORAGE SYSTEM. Spraying water could potentially cool the Thermally activated Pressure Relief Devices (TPRD) and prevent proper operation.
- Hydrogen flames are not visible to the human eye. Hydrogen also burns very quickly and radiates less heat than gasoline. Use a thermal imaging camera to detect for fire.
- The flammability range of hydrogen is 4% to 74% (40,000 to 740,000 ppm) in air. Use a calibrated gas detection device to check hydrogen concentration near the vehicle.
- Do not cut or damage the Compressed Hydrogen Storage System, hydrogen pipes, or hydrogen-related components.
- If vehicle is fueling, shut down fueling operations, if possible.
- First responders and training officers with questions may contact Nikola at **888.690.3050**.

02 IMMOBILIZE AND SHUT DOWN THE VEHICLE



A. Chock the trailer and truck wheels



B. Activate the parking brakes by lifting up on the right side of both the yellow and red switches

C. If the vehicle is on, turn it off by pressing the START | STOP button



03 DISABLE THE HIGH VOLTAGE



- Locate the Manual Battery Disconnect (MBD) access door on the passenger side of the vehicle. Lift the latch and rotate to open the access door.
- Locate the MBD switch
- Turn the MBD switch counterclockwise (CCW) to off
- Wait a minimum of **5 minutes** for the high voltage system to de-energize

MBD ON



MBD OFF



Nikola FCEV

First Responders' Guide

NIKOLA®



WARNING

If the hydrogen is on fire, extinguishing the hydrogen flame completely may cause unburned hydrogen to accumulate and lead to a secondary explosion.

Follow all safety guidelines and procedures before entering the emergency scene.

All personnel should wear and use full firefighting PPE and SCBA as needed at all vehicle fires.

A battery fire may continue after hydrogen has dissipated. Use copious amount of water to extinguish.